



Selecting a Variable Frequency Drive or Soft Starter for Your Application

By: Dave Mintzlaff
WEG Electric Corp. – Duluth, GA

Every AC induction motor needs an electrical control device to start and protect it. Selecting the optimal method of motor control is best approached by considering the connected equipment and what the application demands are. Some processes need to accelerate gradually to full rated speed and then continue to run at constant speed until the process is finished. Others may require the speed to vary continuously throughout the process cycle, accelerating and decelerating at predictable, repeatable ramp rates. Two commonly used motor control devices are the Variable Frequency Drive (VFD) and the Reduced Voltage Soft Starter. Each has advantages and disadvantages. In this article we will discuss the similarities and differences of these two motor controllers and how to determine which of them will best suit your application needs.

Overview

When accelerating an alternating current (AC) motor to full speed using a full voltage connection, a large inrush current may be required. Additionally, the torque of the AC motor is mostly uncontrolled and can shock the connected equipment, potentially causing damage. Variable frequency drives (VFDs) and reduced voltage soft starters can both be used to reduce inrush currents and limit torque; thereby protecting expensive equipment and extending the life of the motor and coupling devices. Choosing between a VFD and soft starter often depends on the type of application, the mechanical system requirements, and cost (both for initial installation and over the lifecycle of the system).



Soft Starters

A reduced voltage soft starter helps protect the motor and connected equipment from damage by controlling the terminal voltage. This limits the initial inrush of current and reduces the mechanical shock associated with motor startup, providing a more gradual ramp up to full speed. Soft Starters are also beneficial to electrical systems with limited current capacity when using a soft starter for motor starting to limit the inrush current. By gradually increasing the motor terminal voltage the soft starter produces a more regulated motor acceleration up to full speed. Soft starters are also capable of providing a gradual ramp to stop where sudden stopping may create problems in the connected equipment.

Applications

Soft starters are used in applications where:

- Speed ramping and torque control are desired when starting or stopping
- High inrush currents associated with starting a large motor need to be limited to avoid supply network issues or penalty charges
- A gradual controlled start is needed to avoid torque spikes and tension in the mechanical system associated with normal equipment startup (e.g., belt-driven systems, gear units, couplings, etc.)
- Avoiding pressure surges or 'hammering' in piping systems when fluid changes speed too rapidly

How Does a Soft Starter Work?

Solid state soft starters use semiconductor devices to temporarily reduce the motor terminal voltage. This provides control of the



motor current to reduce inrush and limit shaft torque. The control is based on controlling the motor terminal voltage on two or three phases. By limiting the voltage to the motor, a reduced torque is provided to start the load more gradually.

Simplified Diagram of a Solid State Reduced Voltage Soft Starter

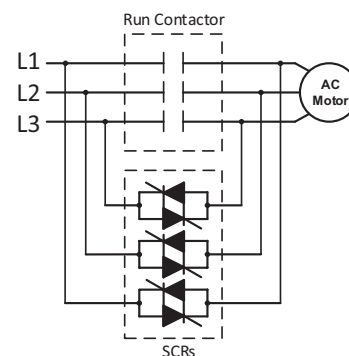

Figure 1. Solid State Soft Starter Main Circuit Diagram

Benefits of Choosing a Soft Starter

Soft starters are often the more economical choice for applications that only require speed and torque control during motor startup. A soft starter can only control the ramping rate during acceleration or deceleration. It cannot be used to vary the operating speed of the motor. Additionally, soft starters are often a solution for applications where space is a concern, as they usually take up less space than comparable VFDs.

Variable Frequency Drives

A VFD is a motor control device that protects and controls the speed of an AC induction motor. A VFD can control the speed of the motor during the start and stop cycle, as well as throughout the run cycle. VFDs are also referred to as adjustable frequency drives (AFD).

Applications

Variable frequency drives are used in applications where:

- Complete speed control is required
- Energy savings is a goal
- Custom control is needed

How Do VFDs Work?

VFDs convert constant frequency and voltage input power to adjustable frequency and voltage source for controlling the speed of AC induction motors. The frequency of the power applied to an AC motor determines the motor speed, based on the following equation:

$$N = \frac{120f}{p}$$

Where:

N = speed (rpm)

f = frequency (Hz)

p = number of motor poles

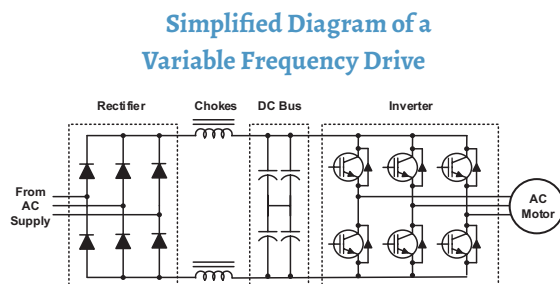

Figure 2. Variable Frequency Drive Main Circuit Diagram

AC Supply: Comes from the facility power network (typically 208V, 230V, 480V, 575V, 690V / 60 Hz AC)

Rectifier: Converts (rectifies) network AC power to DC power

DC Link Chokes and DC Bus: Work together to smooth the rectified DC power and provide clean, DC power to the inverter with low ripple content

Inverter: Uses DC power from the DC bus and chokes to invert an output that resembles sine wave AC power using a pulse width modulation (PWM) technique

Pulse Width Modulation: Switches the inverter semiconductors in varying widths and times that, when averaged, create a sine waveform

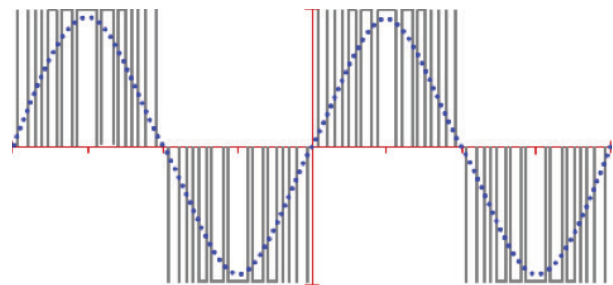

Figure 2. Pulse Width Modulated Waveform Concept

Benefits of Choosing a VFD

Performance

- Fully adjustable speed (pumps, conveyors, fans, etc.)
- Controlled starting, stopping, and acceleration
- Dynamic torque control
- Provides smooth motion for applications such as elevators and escalators
- Maintained speed of equipment, making VFDs ideal for manufacturing equipment and industrial equipment such as mixers, grinders, and crushers

Energy savings

- Reduces peak energy demand
- Reduces power when not required

Versatility

- Self-diagnostics and communications
- Advanced overload protection
- PLC-like functionality and software programming
- Digital inputs/outputs (DI/DO)
- Analog inputs/outputs (AI/AO)
- Relay outputs

Energy savings

VFDs offer the greatest energy savings for centrifugal pumps and fans. The adjustable flow method changes the flow curve and drastically reduces power requirements. Centrifugal equipment (e.g., fans, pumps, and some compressors) follow a general set of speed affinity laws. The affinity laws define the relationship between a set of variables. In this case, the correlation is the pressure change in relation to speed or flow, and the power change in relation to flow. Based on the affinity laws, flow changes linearly with speed while pressure is proportional to the square of speed or flow. The power required is proportional to the cube of the speed or flow. The latter is most important, because if the motor speed drops, the power decreases by the cube.

Let's consider a motor and centrifugal pump or fan operated at 90%, 80%, and 70% of the rated speed. These values can be inserted into the affinity laws formula to calculate the power requirements at these reduced speeds:

$$\frac{\text{Flow}_1}{\text{Flow}_2} = \frac{\text{RPM}_1}{\text{RPM}_2} \quad \frac{\text{Head}_1}{\text{Head}_2} = \left(\frac{\text{RPM}_1}{\text{RPM}_2} \right)^2$$

$$\frac{\text{Power}_1}{\text{Power}_2} = \left(\frac{\text{RPM}_1}{\text{RPM}_2} \right)^3$$

90% speed: $90\%^3$ or $0.90^3 = 0.729$ (72.9%)
provides 27.1% energy reduction

80% speed: $80\%^3$ or $0.80^3 = 0.512$ (51.2%)
provides 48.8% energy reduction

70% speed: $70\%^3$ or $0.70^3 = 0.343$ (34.3%)
provides 65.7% energy reduction

In these examples, the power required to operate the pump or fan at reduced speed is dramatically lower.

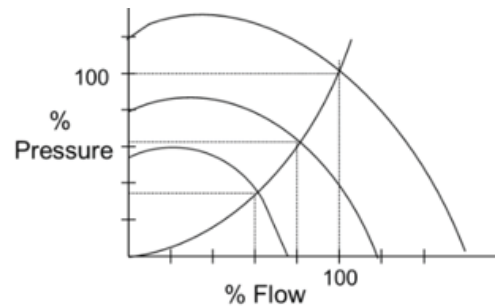

Figure 3. Flow and Pressure Relationship

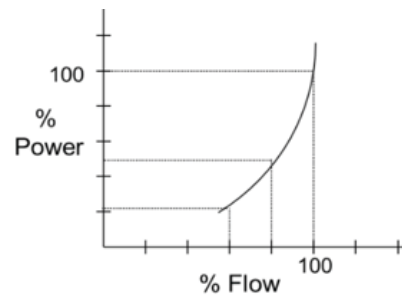

Figure 4. Flow and Power Relationship

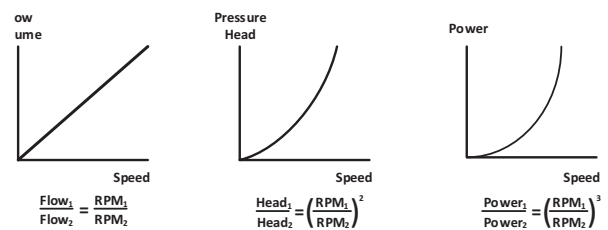

Figure 5. Affinity laws



Selecting the Correct Motor Control Equipment for Your Needs

Choosing a soft starter or VFD often depends on your application. Soft starters are smaller and less expensive when compared with variable frequency drives, especially in larger horsepower applications. Larger VFDs need more space and are usually more expensive than soft starters.

However, while a VFD can be more expensive initially, it can provide significant energy savings which reduces operational cost over the life of the equipment for a lower total cost of ownership.

Speed control is another advantage of a VFD, because they offer consistent acceleration and deceleration throughout the entire operating range of the motor, not just during startup. VFDs can also provide more flexible functionality than soft starters offer, including digital diagnostic information.

It is important to note that a VFD can initially cost as much as two to three times more than a soft starter. Therefore, if constant acceleration and torque control is not necessary, and your application only requires current limiting during startup, a soft starter may be a more cost effective solution for your needs.

David Mintzlaff is Product Line Manager for low voltage drives and soft starters at WEG Electric Corp. in Duluth, Georgia, USA.

For more information on this topic contact:

WEG Electric Corporation
6655 Sugarloaf Parkway
Duluth, GA 30097 USA
www.weg.net/us